

Fig. 3306

Fig. 3307: with Extension Piece

Hydraulic Snubber

Size Range: Eight standard sizes with load ratings from 350 to 120,000 pounds.

Finish: Basic unit is corrosion resistant salt bath nitrided. Attachments are painted with semi gloss primer, carbon zinc or other.

Service: For use on piping systems or equipment when unrestrained thermal movement must be allowed, but which must be restrained during impulsive or cyclic disturbance. The unit is not effective against low amplitude, high frequency movement.

Use with standard settings to prevent destructive response to earthquakes, flow transients or wind load. Special settings are available to absorb the continuous thrust resulting from safety valve blow-off or pipe rupture.

Standard Settings: The standard settings are:

Locking (activation) velocity 8 ± 2 in./min. Bleed rate (post activation) at normal rated load 4 ± 1 in./min.

(Special settings are available). The valves are calibrated at the factory within the tolerances indicated at room temperature. Locking velocity and bleed rate will vary with temperature. Testing has indicated that there is little effect of these changes on dynamic operation.

Features:

- Temperature compensating valves minimize the effects of temperature on lockup and bleed.
- Pressurized reservoirs
- Continuous operation at 150° F with brief transients to 340° F
- Factory calibrated valves
- Rapid, positive valve closure
- Special design minimizes the “lost motion” which results from the shifting and seating of piston seals
- Unlocked resisting force is less than 17 1/2 pounds for sizes 1/4 and 1/2 and less than 2% of rated load for larger sizes
- Stable non-flammable, long life hydraulic fluid
- Self-aligning bushings permit $\pm 5^\circ$ misalignment or angular motion. Bushings are coated with a dry lubricant.
- Choice of coating (paint, primer, carbo zinc, epoxy, plating or other) for attachments.

Applications:

- Direct replacement for Fig. 306/307 Pacific Scientific (PSA) mechanical snubbers: Exact load ratings, exact pin sizes, exact stroke lengths and exact pin-to-pin dimensions. The cross sectional dimensions of the Fig. 3306 are based on those of PSA to facilitate non-interference one-to-one replacement. Pins, clamps, pivot mounts, extension pieces, and rear brackets used with PSA snubbers are compatible with the Fig. 3306 and can be utilized.
- New installations: For new installations, the Fig. 3306 is available with a complete line of pipe clamps and rear brackets.



Fig. 3306



Fig. 3307 with Extension Piece

LOADS (LBS)		
Size	Stroke (in)	Max Load *
1/4	4	350
1/2	2 1/2, 4	650
1	4, 8	1,500
3	5, 10	6,000
10	6, 12	15,000
32	5	32,000
35	6, 18	50,000
100	6	120,000

* Loads must not be applied outside a 10° included angle cone of action to the pipe clamp axis without special authorization.

Fig. 3306 Fig. 3307: with Extension Piece

Hydraulic Snubber

How to size:

- Size:** Use table on the previous page to select size large enough to restrain expected load.
- Stroke:** Define expected movement of the pivot joining the snubber with the equipment to be protected (cold to hot plus any abnormal movements). Determine maximum and minimum distances between this curve and the fixed pivot pin of the snubber. The minimum recommended stroke is 20% greater than the difference between these lengths. Make sure that all normal movement of equipment will be accommodated without the snubber entering the last $\frac{1}{4}$ " (preferably $\frac{1}{2}$ ") of the stroke at either end.
Note: If erected position at the snubber's location on the equipment is outside of the range of normal cold-to-hot movement (e.g cold pull of pipe), the snubber should not be installed until after the equipment is in its cold position. This eliminates the need of providing for the extra travel in the snubber's stroke.
- Piston position:** To aid in measuring the piston position, we have shown a dimension, "Z". This dimension represents the distance between the cylinder head and the end of the rod when the rod is fully retracted. Whenever specifying the position at which the piston rod is to be set, the total dimension from the cylinder head to the end of the rod should be given. Thus, *piston setting = piston position + Z*.
- Assembly length:** Determine the installed "C" dimension by adding the installed piston position (not setting) to C minimum. Lay in takeout dimensions E and/or B, and find required pin-to-pin snubber length. If a pin-to-pin length adjustment is desired, use Fig. 3307. Calculate the required "W" dimension by subtracting (C installed + F) from the required pin-to-pin length. If this is less than W minimum, only a Fig. 3306 can be used, and one of the attachments will have to be moved or shimmed to suit. If a Fig. 3306 is to be used, make sure that the required pin-to-pin length is at least as great as (C installed + B). If neither a Fig. 3306 nor a Fig. 3307 can be accommodated, and the installation cannot be modified, consult your Anvil representative about designing a special or modified unit.
- Installed piston setting:** As indicated previously, the snubber should be installed at its cold piston position if possible. From the installed position, take extension (outward movement) of the piston rod as positive (+) and retraction as negative (-).
Installed piston position =

$$\left(\frac{\text{Stroke} - (\text{Algebraic Sum of Movements})}{2} \right)$$

Ordering: Specify

- Fig. No.
- Size
- Stroke
- Load
- Cold and hot piston settings
- W dimension when specifying Fig. 3307
- Pipe clamp size when specifying option 3
- Attachment surface coating
- Option

FIG. 3306 & 3307 OPTIONS

Option	Consists of...
0	Fig 3306: Basic unit (snubber) with pivot mount and one rear bracket. Fig. 3307: Basic unit with extension piece and one rear bracket.
1	Option 0 plus cylinder eye.
2	Option 0 plus cylinder eye and additional rear bracket.
3	Option 0 plus cylinder eye and pipe clamp.



Fig. 3306

Hydraulic Shock and Sway Suppressor (cont.)

Fig. 3307: with Extension Piece

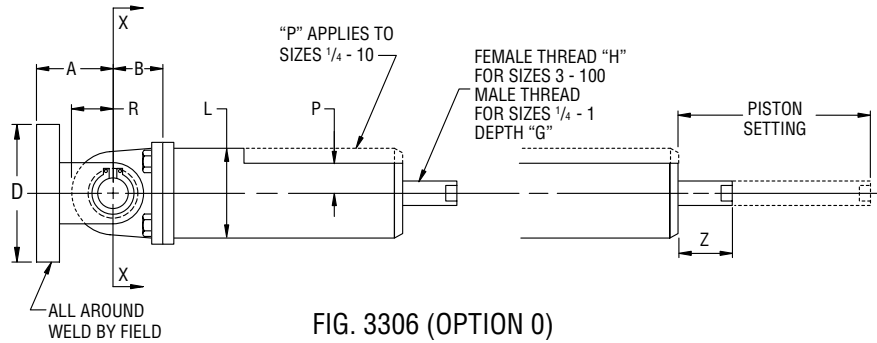

FIG. 3306 (OPTION 0)

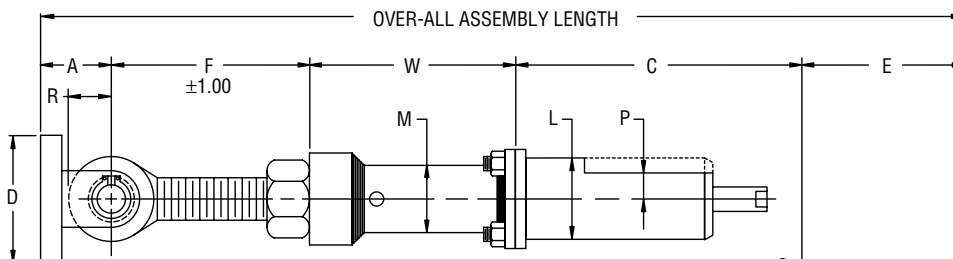
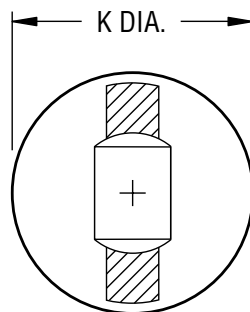
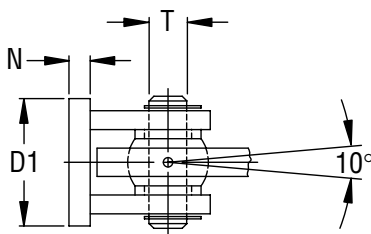

FIG. 3307 (OPTION 0)



BOLT PLATE (SIZES 1/4 - 10)
SECTION X-X

NOTE: CYLINDER EYE MAY BE ROTATED TO ANY POSITION

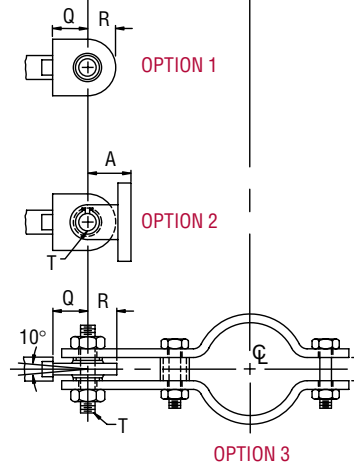

Fig. 3306

Hydraulic Snubber (cont.)

Fig. 3307: with Extension Piece

FIG 3306, 3307 DIMENSIONS (IN)																								
Snubber Size	Stroke	A	B	C *			D	D1	F	G	H	K Dia	L Dia	M Dia	N	P	Q Ref	R Max	S	T Dia	W		Max Pin to Pin	Z
				Min	Mid	Max															Min	Max		
¼	4.00	1.00	1.19	9.0	11.00	13.0	2.00	1.25	2.94	0.38	¾-16-2A	2.25	2.25	1.31	0.25	0.62	1.19	0.63	0.63	0.374 0.372	3.50	45.56	61.50	0.19
½	2.50			7.5	8.75	10.0															3.50	48.56		
	4.00	9.0	11.00	13.0	3.50	45.56																		
1	4.00	1.62	1.56	11.0	13.00	15.0	4.00	1.75	3.00	0.38	¾-16-2A	3.25	2.38	1.31	0.38	0.69	2.00	1.00	1.00	0.499 0.497	3.81	43.50	61.50	0.19
	8.00			15.5	19.50	23.5															N/A	N/A	25.06	0.13
3	5.00	2.12	2.50	14.0	16.50	19.0	5.00	3.62	4.50	0.75	⅝-18-2B	4.62	4.62	2.38	0.50	1.44	2.12	1.38	1.38	0.749 0.747	4.44	37.50	61.00	1.25
	10.00			20.0	25.00	30.0															N/A	N/A	32.62	2.25
10	6.00	3.00	3.40	16.1	19.10	22.1	7.00	4.00	5.12	1.00	⅞-14-2B	5.75	5.75	2.88	1.00	1.62	2.00	1.62	1.38	0.999 0.997	5.19	44.50	71.72	2.10
	12.00			23.1	29.10	35.1															N/A	N/A	39.16	1.00
32	5.00	4.00	2.50	20.75	23.25	25.75	6.12	4.25	-	1.62	1½-12-2B	-	5.00	3.50	1.25	-	3.38	2.50	2.00	1.499 1.497	-	-	-	1.00
35	6.00	4.62	3.00	24.0	27.00	30.0	9.75	6.50	7.75	1.88	1⅝-12-2B	-	6.00	4.50	1.25	-	3.00	2.79	2.00	1.499 1.497	5.25	79.75	117.50	1.48
	18.00			36.0	45.0	54.0								-							14.63	55.75	117.80	
100	6.00	7.25	3.80	29.0	32.00	35.0	14.0	8.75	8.31	3.00	3-12-2B	-	10.00	5.56	2.00	-	3.80	3.44	-	2.499 2.447	6.50	74.19	117.50	3.38

* Adapters are available to match existing pin-to-pins.

FIG 3306, 3307 DIMENSIONS (IN)						
*Pipe Size	E-Take Out					
	Snubber Size					
	¼ & ½	1	3	10	32	35
¾	2⅞	-	-	-	-	-
1	2⅞	-	-	-	-	-
1¼	2⅞	-	-	-	-	-
1½	4⅞	-	-	-	-	-
2	5⅞	-	-	-	-	-
2½	5⅞	7	7	7	-	-
3	5⅞	7	7	8⅞	-	-
3½	6⅞	7	7	8⅞	-	-
4	6½	7¼	7¼	8⅞	-	-
5	7¼	7¾	7¾	9⅞	10	-
6	8⅞	8⅞	8⅞	10	10	-
8	9⅞	9⅞	9⅞	11¼	11¼	12⅞
10	10½	10½	10½	12¼	12¼	14¼
12	-	11⅞	11⅞	13⅞	13⅞	15⅞
14	-	12⅞	12⅞	14½	14½	16
16	-	13⅞	13⅞	15¼	15¼	17⅞
18	-	14⅞	14⅞	16⅞	16⅞	18¼
20	-	15¾	15¾	17¼	17¼	19¼
24	-	18⅞	18⅞	19⅞	19⅞	21¼
30	-	21¼	21¼	23	23	25
36	-	24	24	26½	26½	28⅞

* Intermediate sizes between 20 and 36 are available and will have the take out and stock of the next larger size.

Note: "E" Dimensions are for carbon steel clamps only, with maximum insulation of 4" and temperature of 650°.

